

1 PREPARATION

Checking the Code Number

AC210 Series 2-Electrode Carbon Cells

	AC21	X	/X	X	X	X	X
Insertion Cells							
G1 in. (BSP parallel) thread		1	/3				
1 in. NPT thread		1	/4				
Flow-Through Cells							
Rp 1/2 in. (BSP parallel) thread		2	/1				
1/2 in. NPT thread		2	/2				
Dip (Immersion) and Submersible Cells							
Submersible Cell, Requires dip holder for immersion		3	/0				
Polypropylene dip, length 1m (3.3 ft) with fitted AC213/0 cell		3	/1				
Polypropylene dip, length 2m (6.6 ft) with fitted AC213/0 cell		3	/2				
Cell Constant K							
0.10					3		
1.00					4		
Temperature Compensator							
PT100						1	
Cable Connection Method							
Fixed Cable							1
Terminal Head							2
Detachable Connector							3
Cable Length							
None							0
1m (3.3 ft)							1
2m (6.6 ft)							2
5m (16 ft)							3
10m (33 ft)							4
15m (49 ft)							5
20m (66 ft)							6
Other length – consult factory							9
Language (Manual)							
English							1
French							2
Italian							3
German							4
Spanish							5

AC220 Series 2-Electrode Stainless Steel Cells

	AC22	X	/X	X	X	X	X
Insertion Cells							
G3/4 in. (BSP parallel) thread		1	/1				
3/4 in. NPT thread		1	/2				
Cell Constant K							
0.01					1		
0.10					3		
Temperature Compensator							
PT100						1	
Cable Connection Method							
Fixed Cable							1
Terminal Head							2
Detachable Connector							3
Cable Length							
None							0
1m (3.3 ft)							1
2m (6.6 ft)							2
5m (16 ft)							3
10m (33 ft)							4
15m (49 ft)							5
20m (66 ft)							6
Other length – consult factory							9
Language (Manual)							
English							1
French							2
Italian							3
German							4
Spanish							5

AC200 Replacement/Extension Cables

	AC200	XXX	X
AC200 Cell Extension Cable			
For Terminal Head Versions AC2xx/xxx2			018
For Detachable Connector Versions AC2xx/xxx3			008
Cable Length			
None			0
1m (3.3 ft)			1
2m (6.6 ft)			2
5m (16 ft)			3
10m (33 ft)			4
15m (49 ft)			5
20m (66 ft)			6
Other length – consult factory			9

For operation of AC221 Terminal Head version to 200°C, use high-temperature interconnecting cable 4TB3004-0008. Order quantity by foot.

Cleaning

Before installing the conductivity cell, clean the electrodes, – see Section 6.

2 SITING

Caution. Ensure the integral cable (where applicable) does not touch hot or abrasive objects.

Note. Allow sufficient clearance for easy removal of cell for cleaning – refer to Section 3 for overall dimensions of cells.

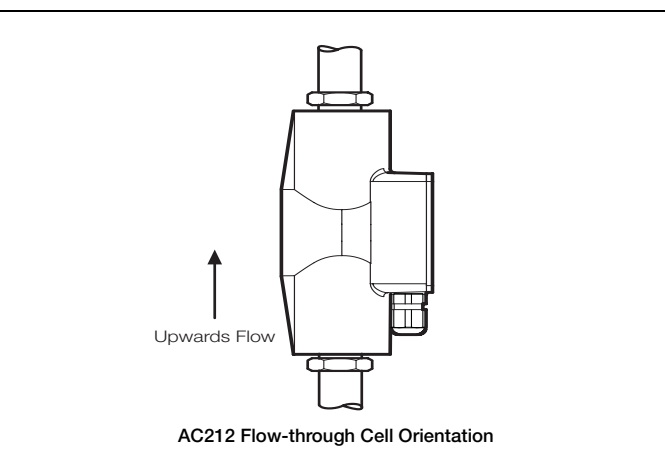
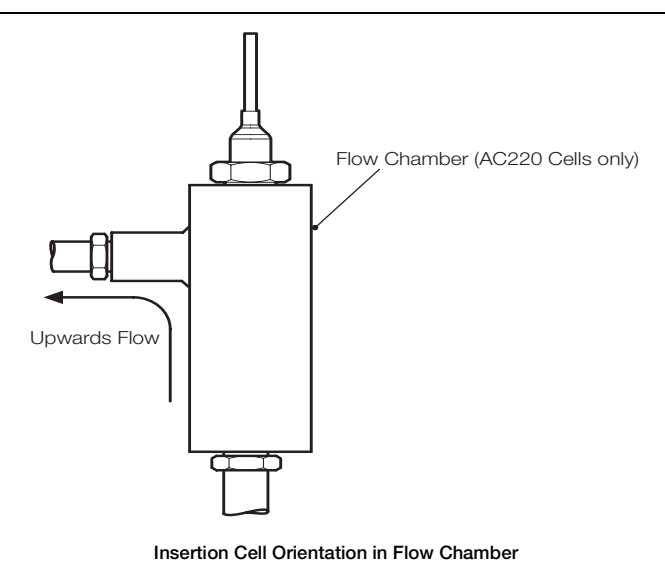
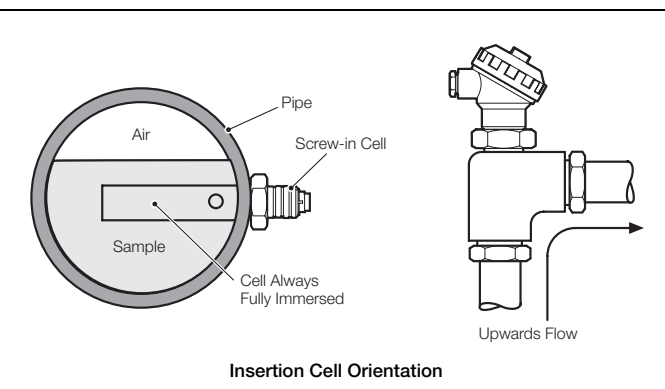

Cell Type	Max. Temperature	Max Pressure	Acid/Alkali Concentration
AC211	100 °C (212°F)	7 Bar A (100psi)	5% Acid 8% Alkali
AC212	100 °C (212°F)	7 Bar A (100psi)	
AC213/0	80 °C (176°F)	10m Water Head (1bar)	
AC213/1 & 2	90 °C (194°F)	2m Water Head (0.2bar)	
AC221 (See Note)	110 °C (230°F)	20 Bar A (290psi)	

Note. This temp rating applies to all AC221 cells. The terminal head versions (AC221/xxx2xx) are rated to 200oC (392oF)*.

*Requires ABB high temperature cable (see bottom left), otherwise rating is as standard AC221 cells.

3 OVERALL DIMENSIONS

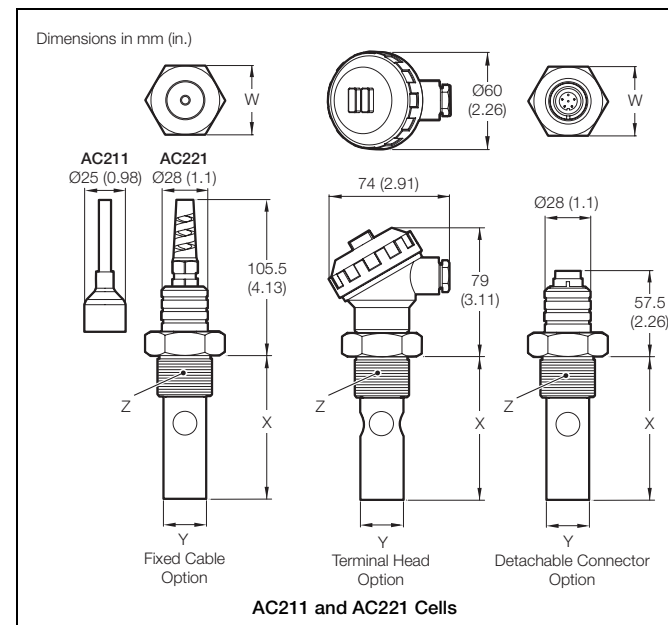

	AC211 Carbon Cells		AC221 Stainless Steel Cells	
	K=1.0	K=0.1	K=0.1	K=0.01
W	42.5 (1.67)		33 (1.3)	
X	123 (4.84)	88 (3.46)	47 (1.85)	91 (3.58)
Y	Ø26.4 (1.04)	Ø26.4 (1.04)	Ø20 (0.79)	Ø16 (0.63)
Z	1in. BSP or NPT Thread		3/4in. BSP or NPT Thread	

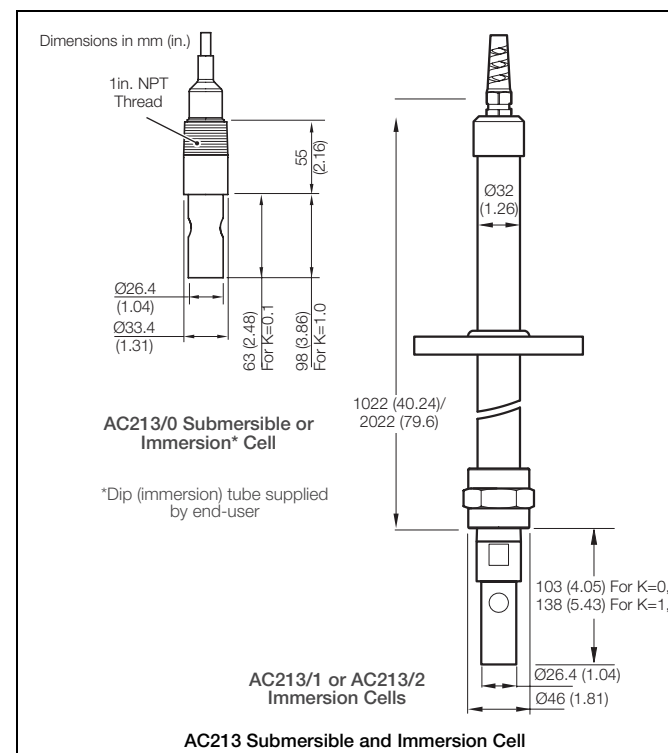
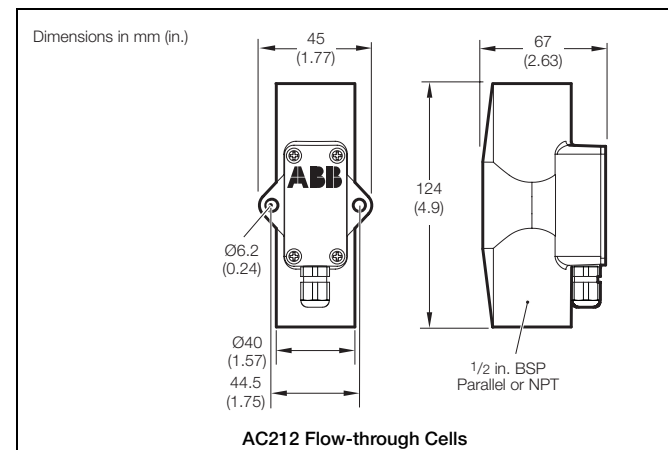

4 INSTALLATION

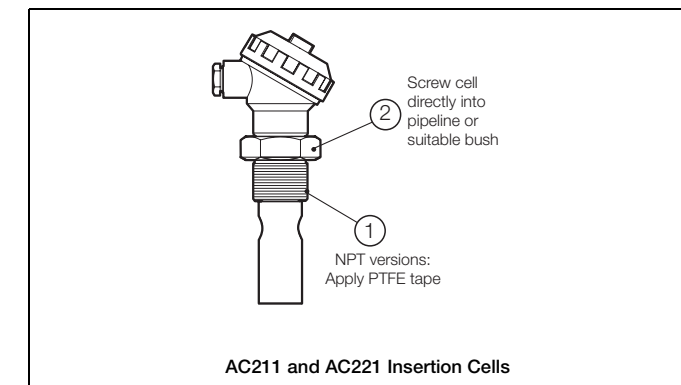

Caution. Overtightening may damage the cell body.

Note. For BSP process connections, a parallel thread must be used.

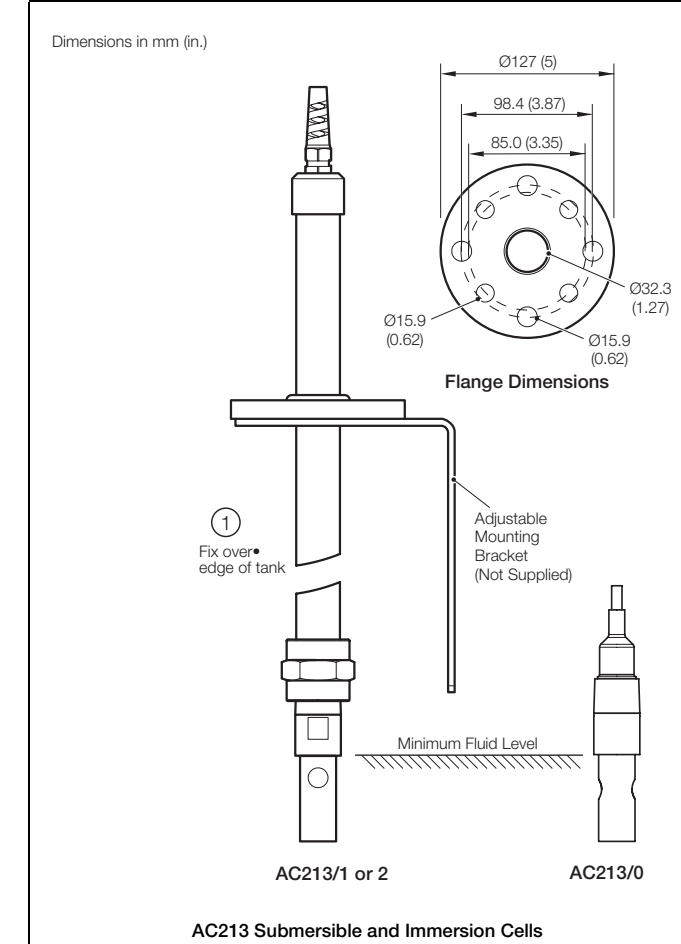
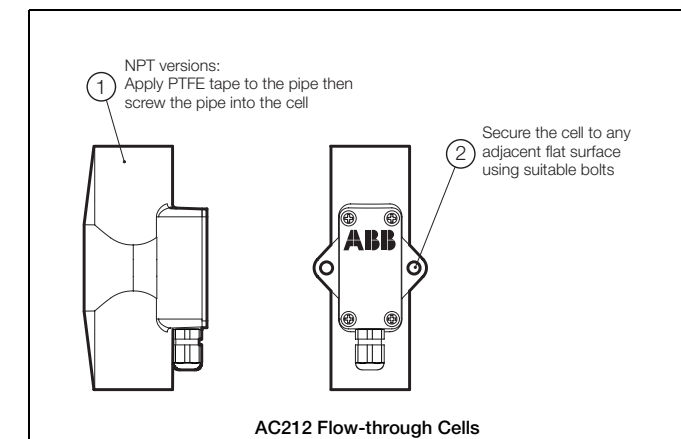

Caution. After cleaning and installing the conductivity cell, ensure that it remains filled with liquid and is not allowed to dry out. Ensure that the electrode bore remains fully immersed at minimum fluid levels.

5 ELECTRICAL CONNECTIONS

Warning. Before making any connections, ensure that the power supply, any high voltage-operated control circuits and high common mode voltages are switched off.

Note. For details of connecting the cable to the analyzer, refer to Section 5.2 or the User Guide for the analyzer.

Terminal Head Connections

Note. The screen is cut back and left unconnected on earthed (grounded) cells.

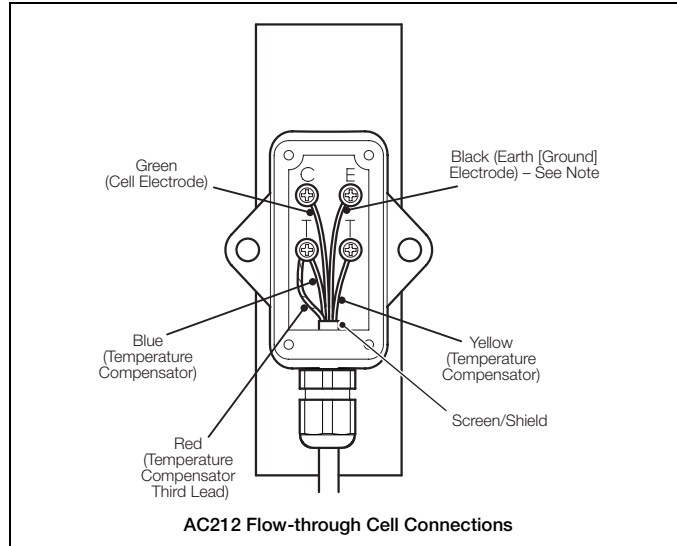
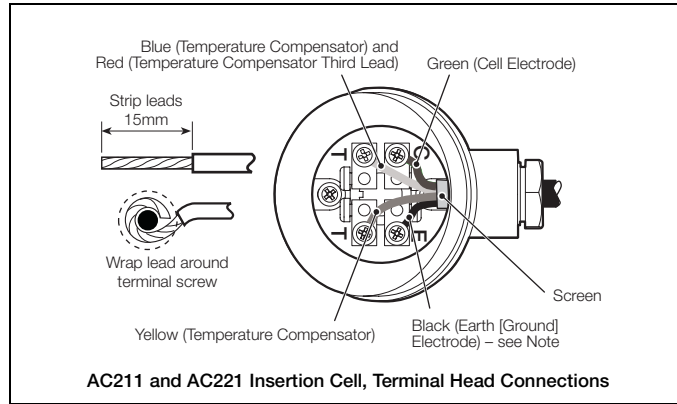

Connections to AX41x, TB82 and 4620 Conductivity Transmitters

	AX41x		TB82TE	4620	4625
	Sensor B	Sensor A			
Blue	B1	B9	TB2-5*	7	9
Red	B2	B10	TB2-5*	6	7
Yellow	B3	B11	TB2-6	5	8
Screen	B4	B12	TB2-7	1	12
Green	B5	B13	TB2-1	3	10
Black	B6**	B14**	TB2-4	4	9

* Wires are connected to the same terminal.

** When connecting non-metal conductivity cells that are isolated from earth (ground), e.g. mounted in plastic, link the following terminals to the earth (ground) stud on the analyzer case:

AX41x Terminal B14
AX411 Terminal B6
4620 Terminal 4
4620 Terminal 9

Notes.

- When connecting earthed (grounded) metal conductivity cells, ensure that the cell earth (ground) and the analyzer earth (ground) are at the same potential.
- The additional white wire is **not** required and can be cut off.
- Do not** mistake the black spacer for the black wire.

6 CLEANING

Caution. While cleaning, do not wet the electrical connection terminals.

6.1 Cleaning the Measuring Cell

Conductivity cells require periodic cleaning, the frequency of which depends on the particular application in which they are employed. Although measuring cells are free of contamination when supplied, they should be cleaned prior to installation.

Caution. Do not touch the cell bore by hand or use sharp implements when cleaning the cell.

6.1.1 A210 Series 2-Electrode Carbon Cells

Thoroughly clean the electrode with a 1:1 solution of water and non ionic detergent using the bottle brush provided. For more tenacious deposits, a 2% hydrochloric acid solution may be used. After cleaning, rinse the cell several times in distilled water and then examine it. Looking through the bore towards a source of illumination, the surface should have an evenly wetted appearance. If the surface has dry patches where the water has 'peeled' away this is an indication of the presence of grease and repeated cleaning and rinsing is required until the cell bore is wetted evenly.

6.1.2 A220 Series 2-Electrode Stainless Steel Cells

Unscrew the outer electrode. Thoroughly clean the electrode with a 1:1 solution of water and detergent using the bottle brush provided. For more tenacious deposits, a 2% hydrochloric acid solution may be used.

After cleaning, rinse the cell thoroughly in distilled water and examine it. With a source of illumination shining into the electrode system, the interior surface of the outer electrode and the whole of the central electrode should have an evenly wetted appearance. If the surfaces have dry patches where the water has 'peeled' away this is an indication of the presence of grease and repeated cleaning and rinsing is required until the electrodes are evenly wetted. Refit the outer electrode.

ABB has Sales & Customer Support expertise in over 100 countries worldwide

www.abb.com

The Company's policy is one of continuous product improvement and the right is reserved to modify the information contained herein without notice.

Printed in UK (10.09)

© ABB 2009

ABB

ABB Limited
Oldends Lane, Stonehouse
Gloucestershire
GL10 3TA
UK
Tel: +44 (0)1453 826661
Fax: +44 (0)1453 829671

ABB Inc.
125 E. County Line Road
Warminster
PA 18974
USA
Tel: +1 215 674 6000
Fax: +1 215 674 7183

IM/AC2CO Issue 8



ABB

Information in this manual is intended only to assist our customers in the efficient operation of our equipment. Use of this manual for any other purpose is specifically prohibited and its contents are not to be reproduced in full or part without prior approval of the Technical Publications Department.

Warning - Refer to the manual for instructions	
Caution - Risk of electric shock	
Protective earth (ground) terminal	
Earth (ground) terminal	
Direct current supply only	
Alternating current supply only	
Both direct and alternating current supply	
The equipment is protected through double insulation	

One or more of the following symbols may appear on the instrument labelling:

Symbols

This instrument complies with the requirements of EN 61010-1:1993 'Safety Requirements for Electrical Equipment for Measurement, Control and Laboratory Use'. If the instrument is used in a manner NOT specified by the Company, the protection provided by the instrument may be impaired.

Electrical Safety

We are an established world force in the design and manufacture of instrumentation for industrial process control, flow measurement, gas and liquid analysis and environmental applications. As a part of ABB, a world leader in process automation technology, we offer customers application expertise, service and support worldwide. We are committed to teamwork, high quality manufacturing, advanced technology and unrivalled service and support. The quality, accuracy and performance of the Company's products result from over 100 years experience, combined with a continuous program of innovative design and development to incorporate the latest technology. The NAMAS Calibration Laboratory No 0255 is just one of the ten flow calibration plants operated by the Company and is indicative of our dedication to quality and accuracy.



Stonehouse, U.K.

Leno, Italy - Cert. No. 9/90A

EN 29001 (ISO 9001)

RMV

ISO 9001

BS EN ISO 9001:2000

Cert. No. Q 05907



BS EN ISO 9001:2000

Client Warranty
Prior to installation, the equipment referred to in this manual must be stored in a clean, dry environment, in accordance with the Company's published specification. Periodic checks must be made on the equipment's condition. In the event of a failure under warranty, the following documentation must be provided as substantiation:
1. A listing evidencing process operation and alarm logs at time of failure.
2. Copies of operating and maintenance records relating to the alleged faulty unit.

Customer Support
We provide a comprehensive after sales service via our Worldwide Service Organization. Contact one of the following offices for details of your nearest Service and Repair Centre.
United Kingdom
ABB Limited
Tel: +44 (0)1453 826661
Fax: +44 (0)1453 827856
United States of America
ABB Inc.
Tel: +1 (0) 775 850 4800
Fax: +1 (0) 775 850 4808

Health and Safety
To ensure that our products are safe and without risk to health, the following points must be noted:
1. The relevant sections of these instructions must be read carefully before proceeding.
2. Warning labels on containers and packages must be observed.
3. Installation, operation, maintenance and servicing must only be carried out by suitably trained personnel and in accordance with the information given.
4. Normal safety precautions must be taken to avoid the possibility of an accident occurring when operating in conditions of high pressure and/or temperature.
5. Chemicals must be stored away from heat, protected from temperature extremes and powders kept dry. Normal safe handling procedures must be used.
6. Safety advice concerning the use of the equipment described in this manual or any relevant hazard data sheets (where applicable) may be obtained from the Company address on the back cover, together with servicing and spares information.